



KRAFTSTOFFMANAGEMENT-SYSTEM



ABGABEEINHEITEN



KITS



PUMPEN



ZÄHLER



ZAPFVENTIL

# CUBE MC

## MERKMALE

- VERWALTUNG MEHRERER BENUTZER
- ALLES IN EINER ANLAGE
- KOMPAKT KONSTRUIERT
- MIT SOFTWARE SSM AGILIS KOMPATIBEL
- ANSAUGFILTER
- IP55

Die PIUSI CUBE MC ist die aktualisierte Ausführung der weltbekannten CUBE-Abgabeeinheit mit elektronischem Bedienfeld, das bis zu 250 Benutzer und 255 Transaktionen verwalten kann. Die robuste Konstruktion umfasst eine selbstansaugende Drehschieberpumpe, einen integrierten Bypass, Automatik-Zapfventil und einen integrierten Zapfventilhalter mit Start/Stop-Pumpenhebel.

### LEISTUNGSPARAMETER

BIS ZU

**70 L/MIN**

VOLUMENSTROM

**AC/DC**

SPANNUNG

**± 0,5%**

GENAUIGKEIT

BIS ZU

**250**

NUTZER

Upgrade ihrer MC-hardware auf B.Smart mit dem upgrade Kit hardware 1.0/2018



CUBE 70 MC MIT SOCKEL (OPTIONAL)



CUBE 70 MC



### VERPACKUNG

CODE	GEWICHT		VERPACKUNG			N. BOX / EUROPALLET	
	KG	LBS	MM	ZOLL	STCK./KARTON	✕	
FO059415D	25	55	400X400X460	-	1	12	24
FO059400E	25	55	400X400X460	-	1	12	24
FO059413D	25	55	400X400X460	-	1	12	24



FILTERUNG



TANKÜBERWACHUNG



SCHLAUCHAUFROLLER



ZUBEHÖR



MERCHANDISE

# PIUSI



ANY BIODIESEL



LUFT



FROSTSCHUTZ



AdBlue®



BIODIESEL



DIESEL



LEBENS.M.



BENZIN



SCHMIERM.



KEROSIN



ÖL



WASSER



WISCHERFLÜSS.

## KENNLINIEN

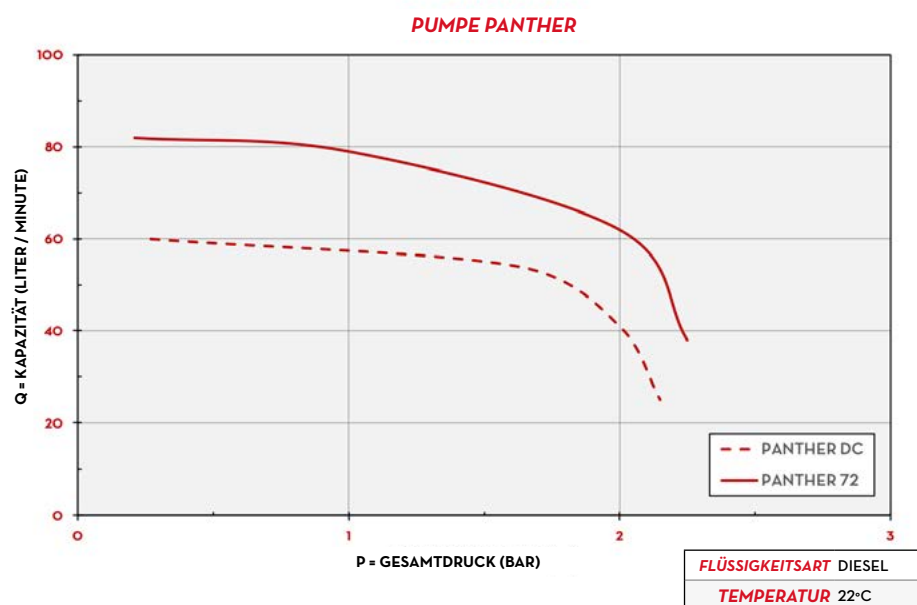

## ABMESSUNGEN

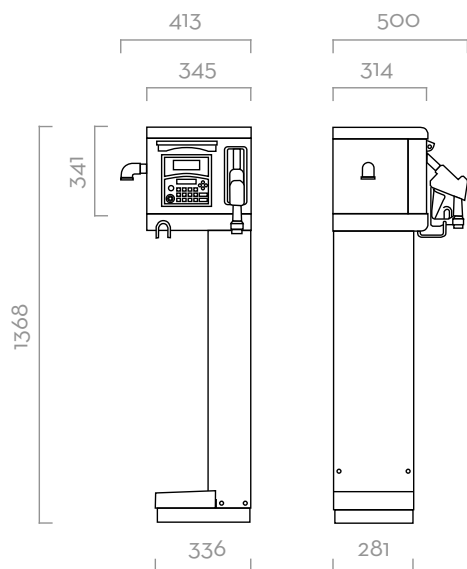

Maße in Millimetern

## LIEFERUMFANG

- CUBE MC-EINHEIT
- AUTOMATIK-ZAPFVENTIL
- VERSORGUNGSSCHLAUCH
- BEDIENUNGSANLEITUNG

## EINZELHEITEN



VERSCHLUSS



NUTZERSCHLÜSSEL  
(NICHT IM LIEFERUMFANG!)

**AGILIS**  
SELF SERVICE  
MANAGEMENT

DATENÜBERTRAGUNG AGILIS

**AGILIS**  
SELF SERVICE  
MANAGEMENT

SSM AGILIS SOFTWARE

## MATERIALIEN

- **PUMPEN:**  
PANTHER AC  
PANTHER DC
- **ZÄHLER:**  
K600/3
- **ZAPFVENTIL:**  
AUTOMATIK-ZAPFVENTIL

## TECHNISCHE DATEN

CODE	BESCHREIBUNG	FLÜSSIGKEITSART	VOLUMENSTROM		SPANNUNG			PUMPE	ZÄHLER	ZAPFVENTIL	FILTER	EINLASS	SCHLAUCH		PC		NUTZER
			L/MIN	GPM	AC V/50HZ	DC VOLT	STROMWATT						AMP. MAX.	TYP	TYP	LÄNGE	
FO059415D	CUBE 70 MC 230V/50HZ 250U AGILIS	D	70	18	230/50	800	3.9	PANTH 72	K600	A60	NEIN	1"	4M	1"	JA	250	
FO059400E	CUBE 70 MC 230V/50HZ 80U AGILIS	D	70	18	230/50	800	3.9	PANTH 72	K600	A60	NEIN	1"	4M	1"	JA	80	
FO059413D	CUBE 70 MC 12V 80U AGILIS	D	60	15	12	420	35	PANTH DC	K600	A60	NEIN	1"	4M	1"	JA	80	

AUF ANFRAGE AUCH MIT UNTERSCHIEDLICHER SPANNUNG UND 60 HZ FREQUENZ LIEFERBAR.